

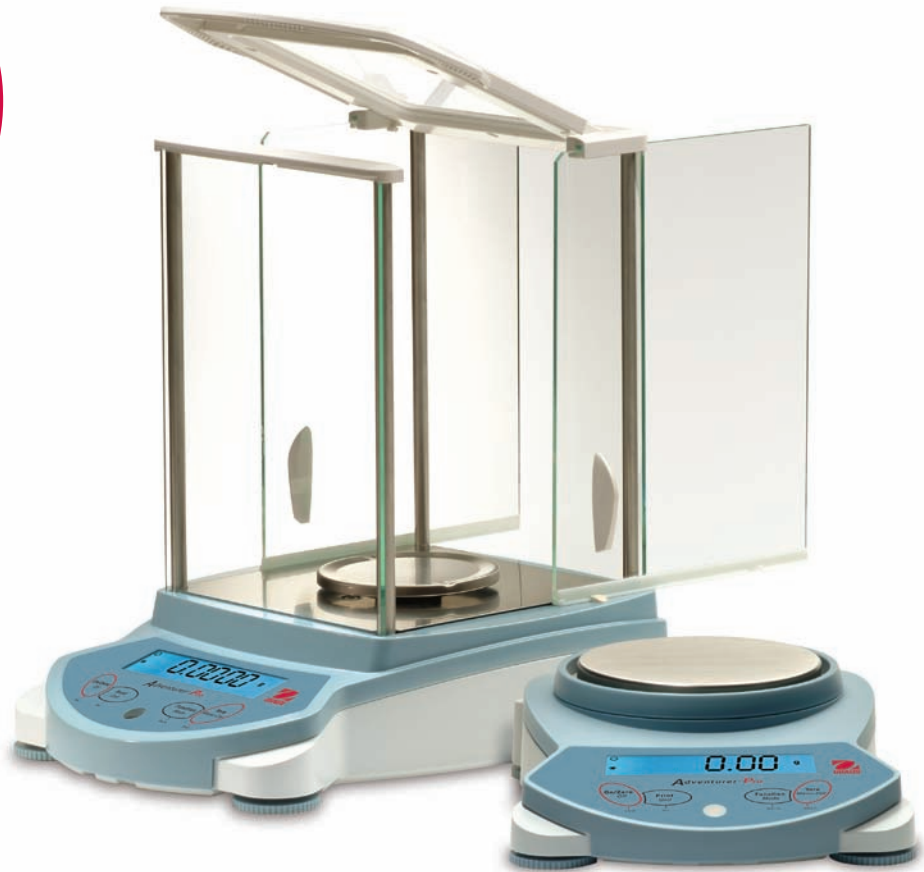

Adventurer™ Pro

Analytical and Precision Balances



The Ohaus Adventurer™ Pro – The Most Complete Balance in Its Class!

The Ohaus Adventurer™ Pro is one of the industry's most versatile balances - it counts, it sums, it holds and it delivers traceable results. With a full range of Analytical and Precision models, no other balance in its class offers all these features in a compact design:

- **Easy Access, Frameless Draughtshield with Removable Doors** – All doors, including the front and back glass panels, disassemble in seconds, and together with a stainless steel base, make it fast and easy to clean.
- **SmarText™ Software Guides Users Through Balance Use** – SmarText™ is Ohaus' easy to use balance software that utilises text prompts to guide users through applications and balance setup.
- **QuadraStance™ Design Provides Superior Footprint Stability** – To enhance weighing stability, QuadraStance incorporates four feet to provide superior footprint stability on any surface.
- **Flexibility of Available Options** – Ensure weighing accuracy with InCal™ internal calibration. A factory installed USB or second RS232 interface allows connection to multiple peripherals.
- **EC Type Approved models available**

Adventurer™ Pro Balances

Frameless Draughtshield With Removable Doors Provides Convenient Access



Users frustrated by navigating tight spaces will welcome the easy-access weighing chamber of the Adventurer Pro. The draughtshield is designed without the need of top rails, so users have unobstructed entry to place or retrieve materials to be weighed. With such unobstructed entry, the chance for accidental spillage is reduced helping to eliminate waste.



With contamination being a concern in today's work environment, all doors, including the front and back glass panels are simple to remove and replace for fast and easy cleaning. Should breakage occur, within 3 easy steps, each replacement door and panel can be installed in seconds.



SmarText™ Software Brings Man and Machine Together

SmarText™ is Ohaus' easy to use balance software that utilises text prompts to guide users through applications use and balance setup. Delivered through a 2-line backlit LCD and clearly marked buttons, SmarText tells you what is going on and what you have to do next.

Utilising the 2-line LCD, SmarText simultaneously displays weight and application specific information such as percent or count. For example, with one touch of the Function button, SmarText will display application reference information such as average piece weight (APW), while displaying a parts count.



QuadraStance™ Design for Superior Stability

QuadraStance™ incorporates four adjusting feet to provide superior footprint stability on any surface. QuadraStance helps prevent rocking and tipping, enhancing the weighing stability of the balance, and keeping the Adventurer *Pro* level and accurate.

Additionally, Adventurer *Pro* has been designed with a front level indicator eliminating the need to look behind the balance during the leveling process. A quick glance at the level indicator helps to ensure that the balance is level prior to each use.



Added Flexibility of Available Options

The Adventurer *Pro* also offers InCal™ internal calibration. InCal ensures weighing accuracy by allowing you to calibrate the balance prior to use without the need of external weights.

All Adventurer *Pro* models come with a built-in RS-232 interface, and for added functionality can be equipped with either a second RS-232 or USB interface, allowing connections to multiple peripherals. With full GLP/GMP data output, Adventurer *Pro* can meet traceability and compliance requirements.



Other Standard Features Include:

Multiple Application Modes Including:

- Dynamic Weighing Mode – Allows the user to weigh small animals and filters out animal movements to provide a stable weight indication
- Parts Counting with Optimisation – Allows the user to count based on a calculated piece weight. With optimisation, counting accuracy is improved through auto re-calculation of the piece weight
- Percentage Mode – Allows the user to display the weight of a sample as a percentage of a reference weight
- Checkweighing Mode – Allows the user to check the weight of a sample against a preset target
- Totalisation Mode – Allows allows the user to sum a series of sample weights
- Display Hold Mode – Allows the user to hold the highest stable weight on the display until cleared



Selectable Environmental Settings

- Three filter modes and adjustable zero tracking are ideal for working in slow filling applications where sensitivity is a must. When working in harsh environments, the user can adjust balance settings to compensate for vibrations and other disturbances.

Protective In-Use Cover

The in-use cover is replaceable and offers protection against dust and debris, minimising the chance of damage to the display and keypad buttons.

Adventurer™ Pro Balances

Feature Rich: Adventurer Pro Is The Most Complete Balance In Its Class



Security
To prevent unwarranted movement or theft, an integrated security bracket

accommodates the security device accessory

Easy to Clean
Adventurer Pro's stainless steel platform and removable wind ring make it extremely easy to clean



Connectivity
Adventurer Pro comes with an RS232 interface. A second RS232 or USB interface is also available as a factory installed option

Easy to View Display
Adventurer Pro features a 2-line alphanumeric LCD with brilliant backlight. Portable models include a backlight auto-off feature to conserve battery life

AC and / or Battery Power
Some models offer portability and can operate on either the included AC adapter, or on 4 "AA" batteries. An Auto Shutoff feature helps conserve battery life



Weigh-Below Hook
Adventurer Pro's integral weigh-below hook allows density determination or calculating the specific gravity of samples



Multiple Weighing Units
Adventurer Pro features multiple weighing units including a user-defined custom unit for use in unique weighing applications

Easy to Use Keypad
Four-button keypad with dedicated YES, NO, BACK and EXIT functions simplify menu navigation and balance set-up



General Specifications

Weighing Units*	Milligram, Gram, Kilogram, Ounce, Pound, Carat, Pennyweight, Ounce Troy, Grain, Newton, Hong Kong Tael, Singapore Tael, Taiwan Tael, Momme, Tical, Baht, Mesghal, Tola, Custom
Application Modes	Weighing, Dynamic Weighing, Parts Counting with Automatic Sample Recalibration, Percent Weighing, Checkweighing, Totalisation, Display Hold
Tare Range	To capacity by subtraction
Operating Temperature Range	10° - 30°C
Calibration	Digital with External Weight (non-"C" models) Digital with Internal Weight ("C" models with InCal option)
Display Type	2-Line Alphanumeric Backlit LCD Display
Display Size (in/cm)	10 x 2.5

* Milligram unit available on 0.1mg to 1mg models
Kilogram and Pound units available on 0.01g to 0.1g models

Technical Specifications, Precision Balances

Capacity (g)	210	310	410	210	410	810	2100	3100	4100	2100	4100	8100
Readability (g)	0.001			0.01			0.01			0.1		
Approved Readability (g) (...M models only)	0.01			0-50 / 51-210 0.01 / 0.02	0-50 / 51-410 0.01 / 0.05	0.1			0-500 / 501-2100 0.1 / 0.2	0-500 / 501-4100 0.1 / 0.5	1	
Repeatability (Std. dev.) (g)	0.001			0.01			0.01			0.1		
Linearity (g)	± 0.002			± 0.02			± 0.02			± 0.2		
Stabilisation Time (seconds)	3			1.5*	3			2*				
Power Requirements w/ InCal	AC Adapter (Included)											
Power Requirements w/o InCal	AC Adapter			AC Adapter (Included) or 4 AA Batteries (not included)			AC Adapter			AC Adapter (Included) or 4 AA Batteries (not included)		
Draughtshield Type with Height Over Pan (cm)	Square: 11.5	None										
Pan Size with InCal (cm)	12 dia.			16.8 x 18			16.8 x 18			14.9 x 16.2		
Pan Size without InCal (cm)	12 dia.			14.9 x 16.2			16.8 x 18			14.9 x 16.2		
Balance Dimensions w/ InCal W x H x D (cm)	22 x 19 x 30	22 x 8.5 x 30										
Balance Dimensions w/o InCal W x H x D (cm)	22 x 19 x 30			19.3 x 7.2 x 25.4			22 x 8.5 x 30			19.3 x 7.2 x 25.4		
Shipping Dimensions w/ InCal W x H x D (cm)	39 x 41 x 50			39 x 33 x 50			39 x 33 x 50			27.6 x 16 x 38.5		
Shipping Dimensions w/o InCal W x H x D (cm)	39 x 41 x 50			27.6 x 16 x 38.5			39 x 33 x 50			27.6 x 16 x 38.5		
Net Weight w/InCal (kg)	3.7			2.6	3.4	3.2			3.5			
Net Weight w/o InCal (kg)	3.3			1.2	1.5	2.8			1.6			
Shipping Wt w/ InCal (kg)	6.6			5.4	6.2	6.1			6.3			
Shipping Wt w/o InCal (kg)	6.2			2.2	2.4	5.7			2.5			
Item Number w/ InCal Internal Calibration	AV213C	AV313C	AV413C	AV212C	AV412C	AV812C	AV2102C	AV3102C	AV4102C	AV2101C	AV4101C	AV8101C
Item Number w/o InCal Internal Calibration	AV213	AV313	AV413	AV212	AV412	AV812	AV2102	AV3102	AV4102	AV2101	AV4101	AV8101
Item Number EC Type Approved w/o InCal Internal Calibration**	---	---	---	AV212DM	AV412DM	AV812DM	---	---	---	AV2101DM	AV4101DM	AV8101DM
Item Number EC Type Approved w/ InCal Internal Calibration	AV213CM	---	AV413CM	AV212CDM	AV412CDM	AV812CDM	AV2102CM	---	AV4102CM	AV2101CDM	AV4101CDM	AV8101CDM

*Note: Models AV212C, AV2101C, AV4101C and AV8101C have a stabilization time of 3 seconds

**Requires 2nd stage verification on place of use by authorised organisation

Note: EC type approved class II, approval no.: D05-09-029 or D04-09-033

Outline Dimensional Drawings, Precision Balances

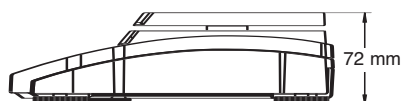

Models AV212, AV412, AV812, AV2101, AV4101, AV8101

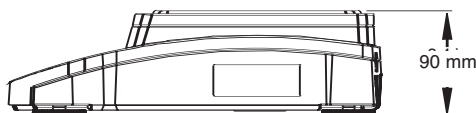

Models AV2102, AV3102, AV4102

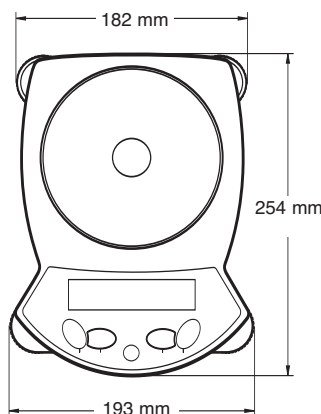

Models AV212, AV412, AV812,
AV2101, AV4101, AV8101

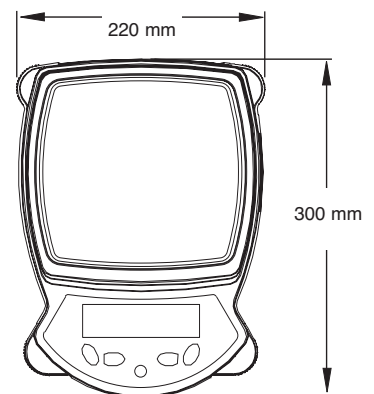

Models AV213, AV213C, AV313, AV313C, AV413, AV413C,
AV212C, AV412C, AV812C, AV2102, AV2102C,
AV3102C, AV4102, AV4102C, AV2101C, AV4101C, AV8101C

Models AV212, AV412, AV812, AV2101, AV4101 and AV8101 feature battery capability and a full protective in-use cover

Adventurer™ Pro Balances

Technical Specifications, Analytical Balances

Capacity (g)	110	260
Readability (mg)	0.1	
Approved Readability (mg) (...M models only)	1	
Repeatability (Std. dev.) (mg)	0.1	
Linearity (mg)	± 0.2	
Stabilisation Time (seconds)	3	
Power Requirements	AC Adapter (Included)	
Draughtshield Type w/ Height Over Pan (cm)	Square: 22	
Pan Size (cm)	9 dia.	
Balance Dimensions W x H x D (cm)	22 x 30.5 x 30	
Shipping Dimensions W x H x D (cm)	39 x 52.5 x 50	
Net Weight w/InCal (kg)	4.4	
Net Weight w/o InCal (kg)	4	
Shipping Weight w/ InCal (kg)	7.4	
Shipping Weight w/o InCal (kg)	7	
Model Number w/ InCal Internal Calibration	AV114C	AV264C
Model Number w/o InCal Internal Calibration	AV114	AV264
Model Number EC Type Approved w/ InCal Internal Calibration	AV114CM	AV264CM

Note: EC type approved class I, approval no.: D05-09-029

Outline Dimensional Drawings, Analytical Balances

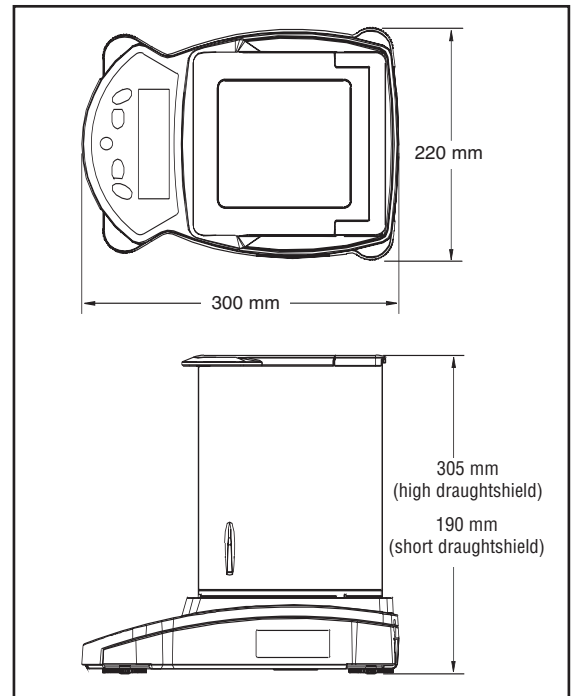

Other Standard Features and Equipment

Stability indicator, mechanical and software overload/underload protection, low battery indicator, AC adapter, user selectable span calibration points, auto tare, user selectable printing options, user selectable communications settings, user selectable data print options, user definable project and user ID's, software reset menu, software lockout menu

Approvals

CE, FCC, cUL_{US}, cCSA_{US}, NRTL

C Tick

CB Scheme

IP33 (without Power Adapter; with Pan put on)

IP20 (with Power Adapter, with Pan put on)

Options and Accessories

Ohaus Number

USB Interface	Contact Ohaus for Details
2nd RS232 Comm Port	Contact Ohaus for Details
Impact printer, 42 column	SF42
RS232 cable, SF42 printer	21253677
SF42 printer paper (5 pack)	00065975
SF42 printer ribbon	00072456
RS232 cable, IBM 9 pin	00410024
RS232 cable, IBM 25 pin	80500524
Density determination kit for 0.1/1mg balances	80850045
Security device	80850000
Calibration masses	Contact Ohaus for Full Offering
Sample Scoops	Contact Ohaus for Full Offering

Industry Leading Quality and Support

All Ohaus Adventurer™ Pro balances are manufactured under an ISO 9001:2000 Registered Quality Management System. Our rugged construction and stringent quality control have been hallmarks of all Ohaus products for nearly a century.

www.ohaus.com

* ISO 9001:2000

Registered Quality Management System

80774160B © Copyright Ohaus Corporation

